

Innen- und Aussenkuehlung / Inside and outside coolant supply
Kuehlmittelfiltrierung50μ / coolant filtration50μ

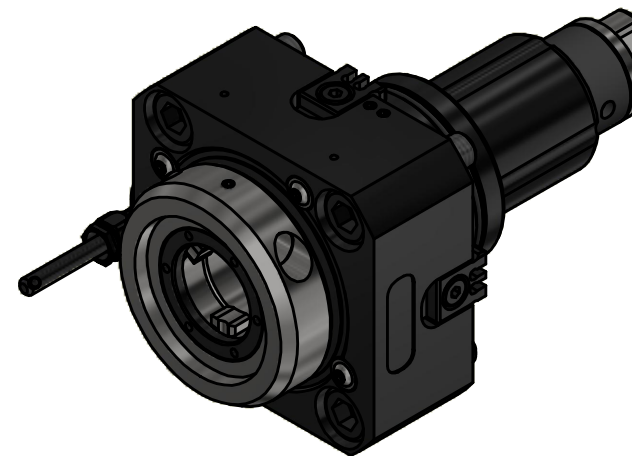

Copyright **EWS Tool Technologies**
Weitergabe und Vervielfaeltigung dieser Unterlage,
Verwertung und Mitteilung ihres Inhalts nicht
gestattet, soweit nicht ausdrecklich zugestanden.
Zuwiderhandlungen verpflichten zu Schadenersatz.

Bemerkung - Note
Für Trockenlauf geeignet!
Use without coolant fluid allowed!

Technische Daten - technical data	
Weight	= 4.073 [kg]
Torque max. (M1/M2)	= 63 / 63 [Nm]
Speed max. (n1/n2)	= 6000 / 6000 [1/min]
Gear ratio (i)=n1:n2	= 1:1
Pressure (pmax)	= 70 [bar]

Benennung - Title
Axial Bohr und Fräskopf
Axial drilling and milling head



Technische Aenderungen vorbehalten!
Subject to technical modifications!

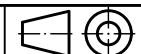

REV: -/A

Nr. - No.
542-010655

MNR.

