

EWS.Varia

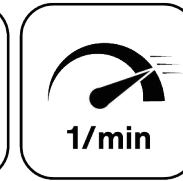

Ceramic Seal



Highspeed

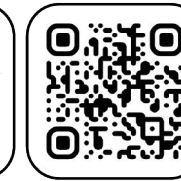

Tech Details

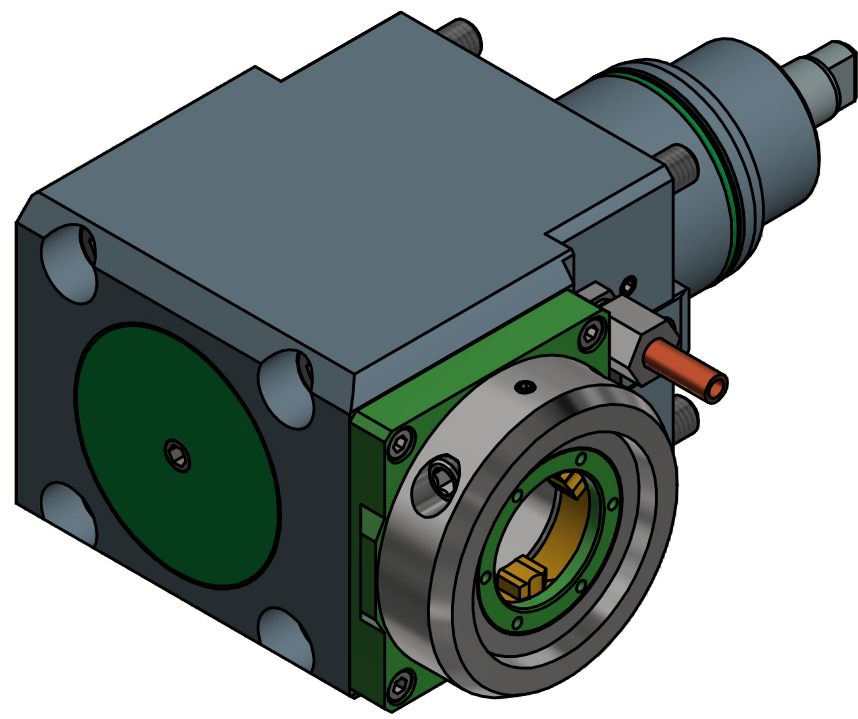
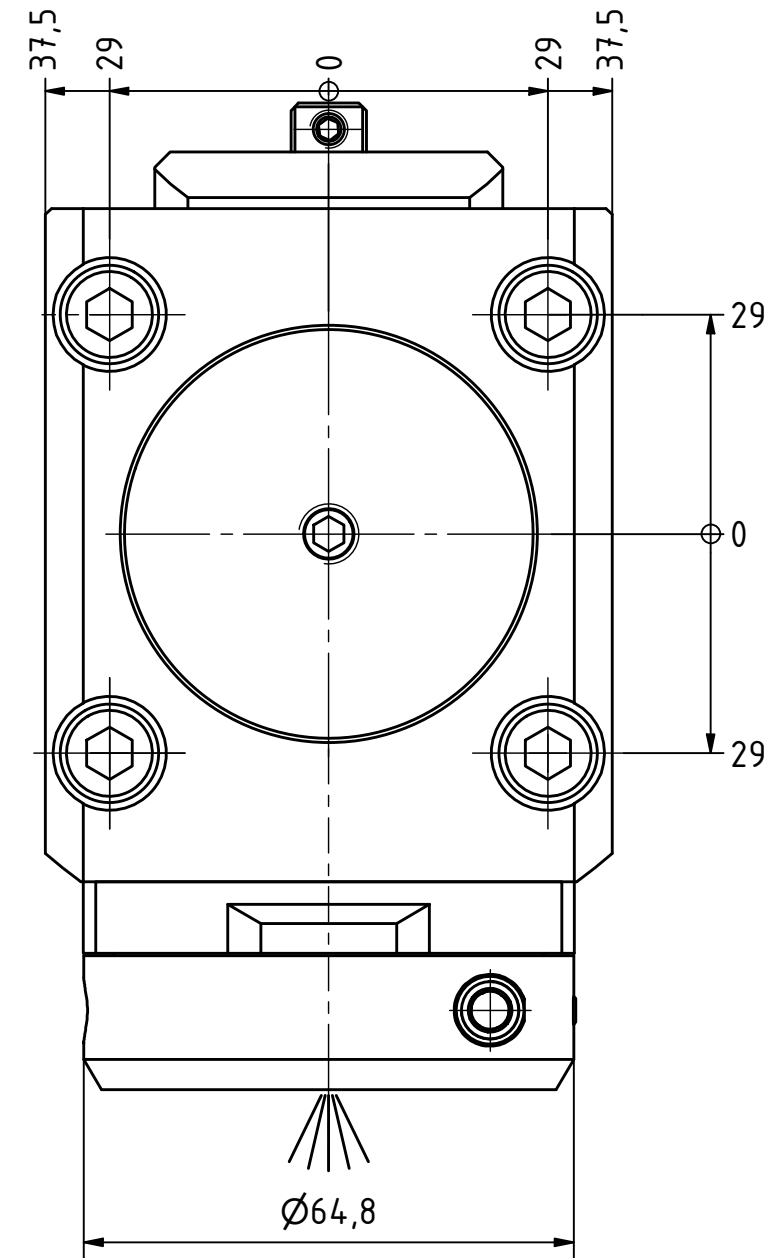
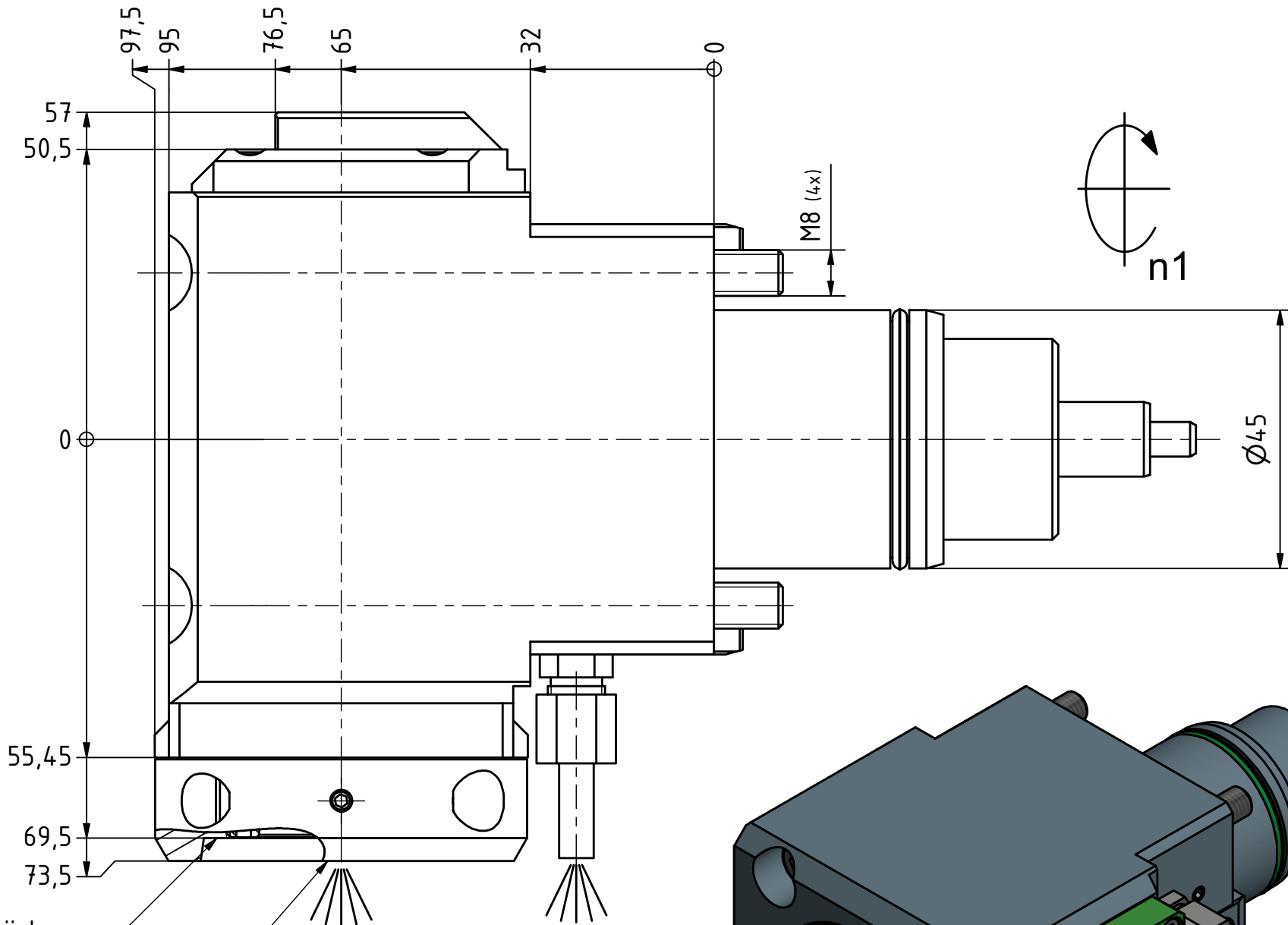

Anlagefläche
contact surface

EWS-Varia VX3

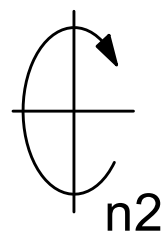

Innen- und Aussenkuehlung / Inside and outside coolant supply
Kuehlmittelfiltrierung<50µ / coolant filtration<50µ

Copyright **EWS Tool Technologies**
Weitergabe und Vervielfaeltigung dieser Unterlage,
Verwertung und Mitteilung ihres Inhalts nicht
gestattet, soweit nicht ausdrecklich zugestanden.
Zuwiderhandlungen verpflichten zu Schadenersatz.

Bemerkung - Note
Für Trockenlauf geeignet!
Use without coolant fluid allowed!

Technische Daten - technical data

Weight	= 4.927 [kg]
Torque max. (M1/M2)	= 25 / 25 [Nm]
Speed max. (n1/n2)	= 12000 / 12000 [1/min]
Gear ratio (i)=n1:n2	= 1:1
Pressure (pmax)	= 70 [bar]

Benennung - Title

Radial Bohr und Fräskopf
Radial drilling and milling head



Nr. - No.
542-010679

Technische Aenderungen vorbehalten!
Subject to technical modifications!

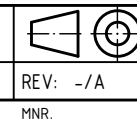

REV: -/A
MNR.

