

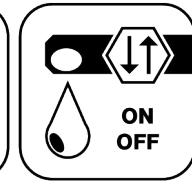

Butterfly Seal

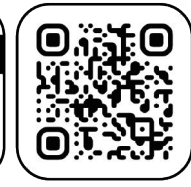

Coolant Management



Tech Details

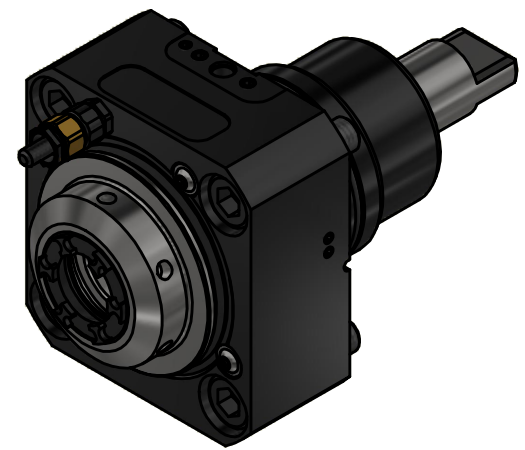
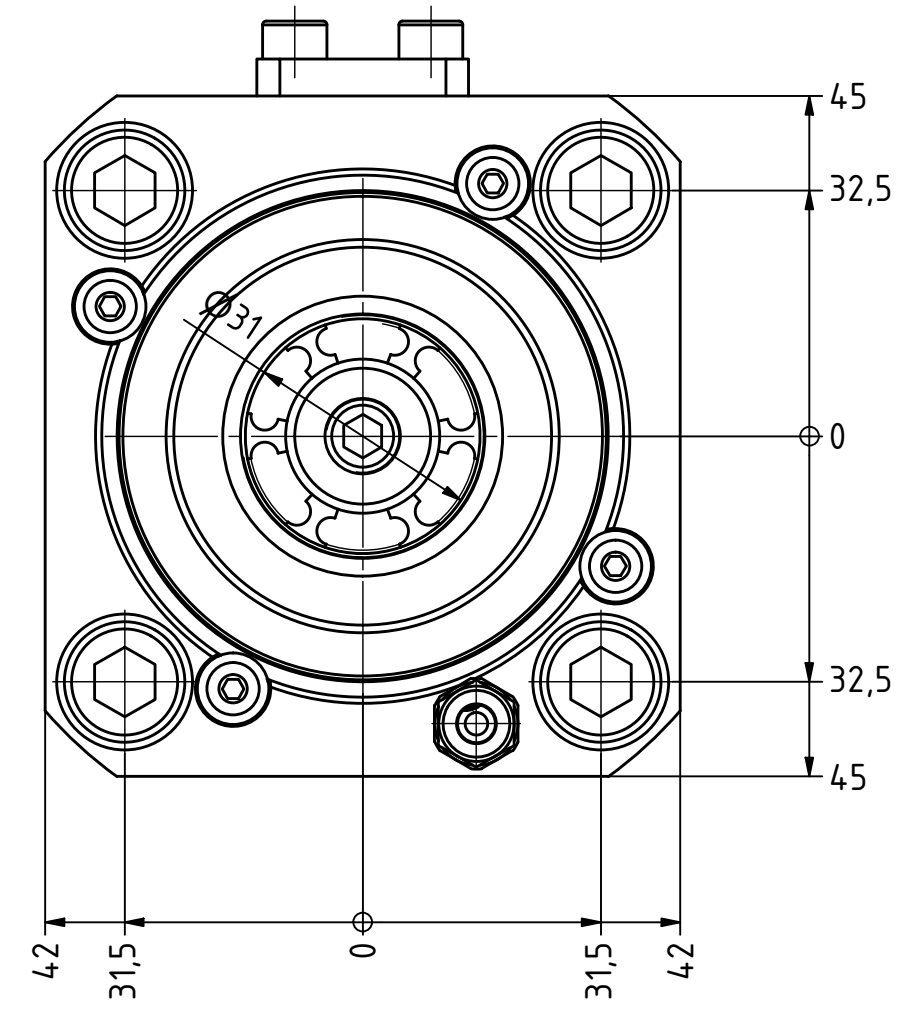
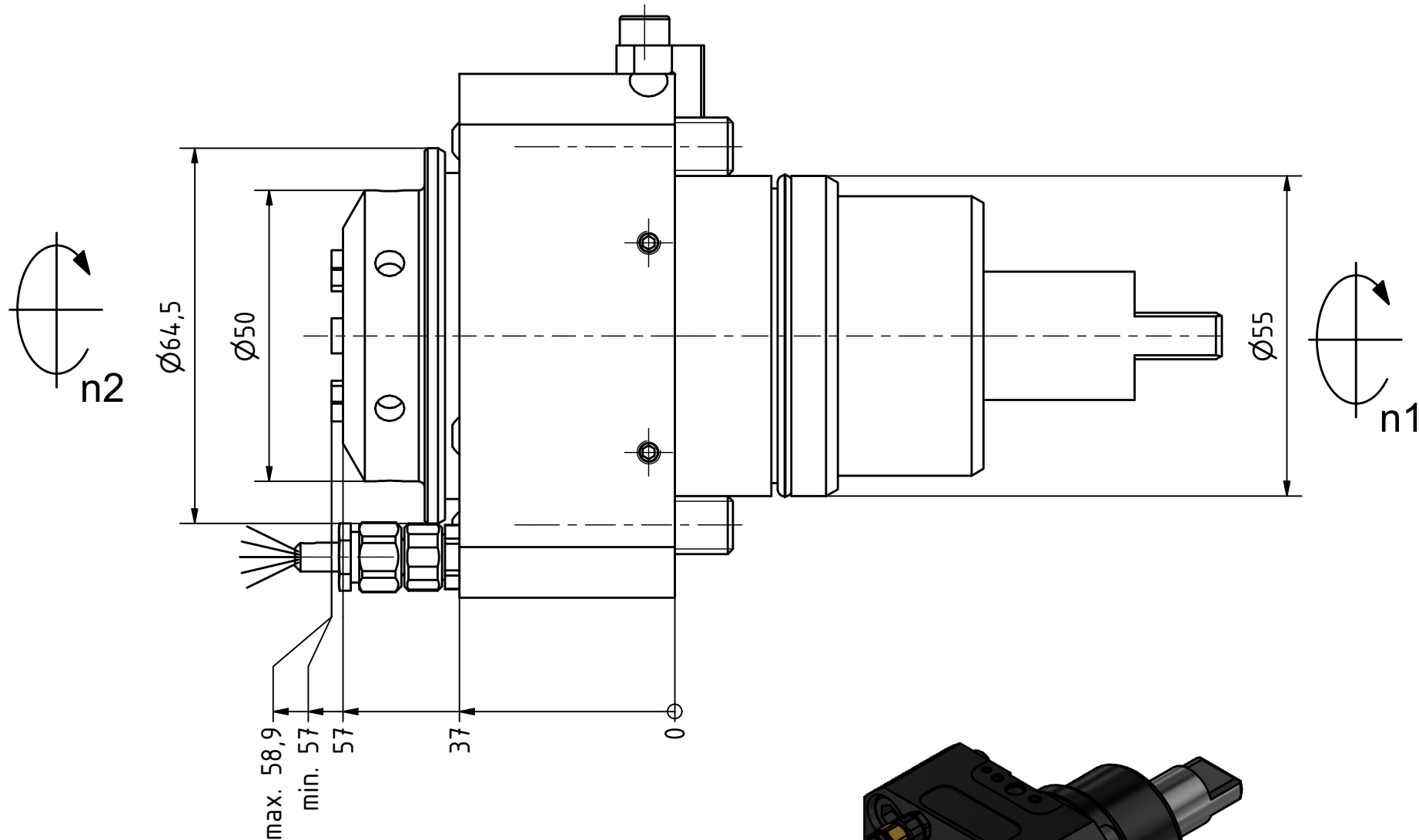

Spannzange / collet ER25 DIN6499
 Spannungsbereich / clamping range: 1,0 - 16,0

Gewindebohrzange / tapping collet
 ET-1-25 M3-M12

 Hakenschlüssel
 mit Zapfen
 Hook wrench
 with fixed pin
 DIN1810 B 45x50

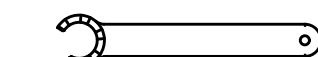
 Spannzangenschlüssel für
 innenliegende Mutter
 Clamping wrench for
 internal collet
 225AX

Copyright **EWS Tool Technologies**
 Weitergabe und Vervielfältigung dieser Unterlage,
 Verwertung und Mitteilung ihres Inhalts nicht
 gestattet, soweit nicht ausdrücklich zugestanden.
 Zuwiderhandlungen verpflichten zu Schadenersatz.

Bemerkung - Note
 mit Kegelrollenlager
 with taper roller bearing(s)

Technische Daten - technical data
 Weight = 2.966 [kg]
 Torque max. (M1/M2) = 63 / 63 [Nm]
 Speed max. (n1/n2) = 5000 / 5000 [1/min]
 Gear ratio (i)=n1:n2 = 1:1

Benennung - Title

EWS Tool Technologies
 EWS Weigle GmbH & Co. KG
 Maybachstr. 1
 D-73066 UHINGEN
 www.ews-tools.de

Technische Änderungen vorbehalten!
 Subject to technical modifications!

REV: -/A

Nr. - No.
 542-010718

